

# PARTS LIST & DIAGRAM



## A-910 / A-928 HVLP SPRAY GUN

### NOZZLE SIZING - A-928 HVLP AIR SPRAY

There are 4 different basic sizes of fluid nozzle available:

#### Material being sprayed

Clear lacquers, thin stains, ..... 1.0 mm diameter (.039")  
 most industrial enamels, automotive paints.

Color or high build lacquers, metal primers, ... 1.4 mm diameter (.055")  
 semi gloss oil paints, other moderate viscosity products... (standard)

Latex and oil paints, multicolor, primers. .... 2.0 mm diameter (.079")

Special applications. .... 2.8 mm diameter (.110")

#### Replacement #1a air cap order numbers:

L015-865 Air cap only for A910 - 1.1mm  
 L015-866 Air cap only for A910 - 1.4mm  
 L015-867 Air cap only for A910 - 1.8mm  
 L015-868 Air cap only for A910 - 2.0mm  
 L015-869 Air cap only for A910 - 2.5mm

L015-786 Air cap only for A928 - 1.0mm  
 L015-787 Air cap only for A928 - 1.4mm  
 L015-788 Air cap only for A928 - 1.7mm  
 L015-789 Air cap only for A928 - 2.8mm

### Nozzle chart

Material	1.0 mm	1.4 mm	2.0 mm
clear finishes (up to 20 sec)	best	ok	no
colour finishes (20 - 40 sec)	ok	best	ok
multicolour & heavy latex (40+ sec)	no	no	best

#### HD needle shut off for some pressure feed applications:

Some heavy bodied materials and/or higher pressures may cause nozzle dripping. In this case HD spring #10 L015-527 will strengthen the shut off.

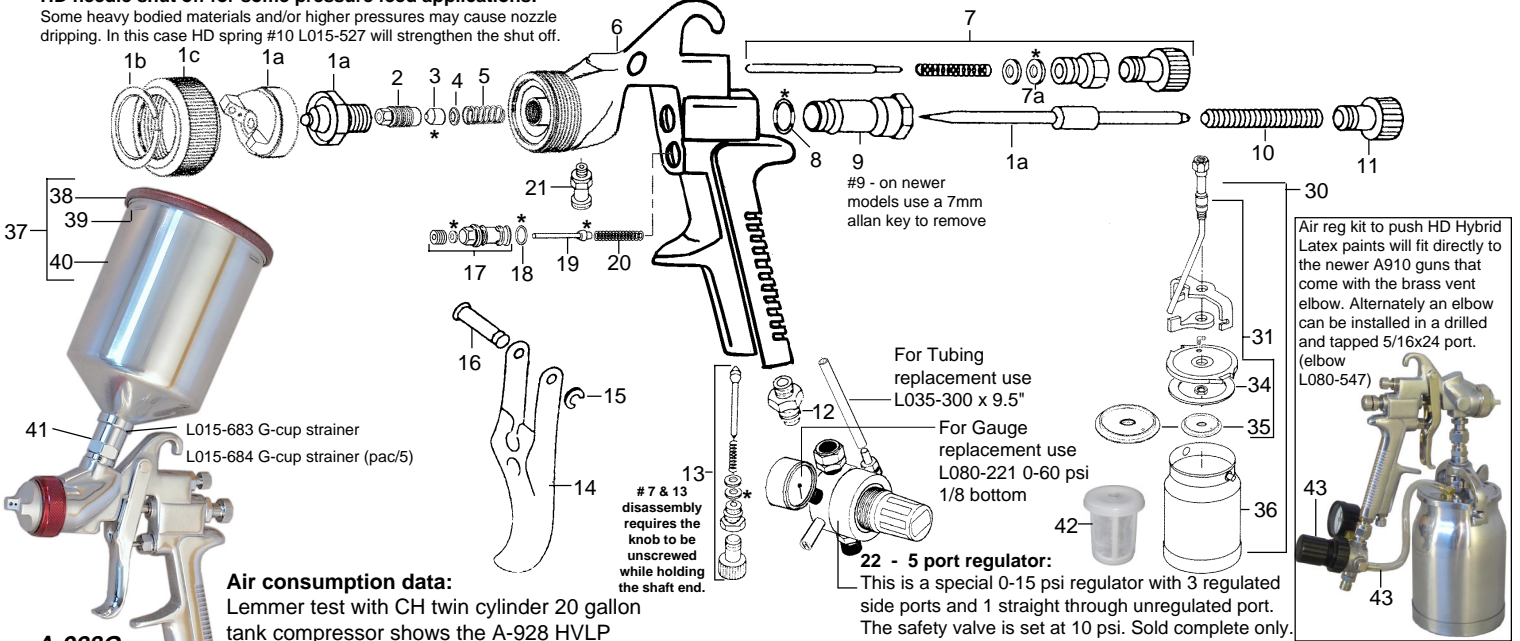

#### Air consumption data:

Lemmer test with CH twin cylinder 20 gallon tank compressor shows the A-928 HVLP holding about 50 psi continuous. Needle and fan size do not greatly affect air consumption which is approximately 7cfm @ 50psi.

Pos.	Part nos.	Description	Qty.
	L015-020	A-928S HVLP spray gun with press. cup	
	L015-021	A-928P HVLP press feed (no reg, no cup)	
	L015-022	A-928G HVLP with 600ml cup	
	L015-012	A-910S with 1L S cup	
	L015-013	A-910PSS press feed (no reg, no cup)	
	L015-017	A-910PSS with 950ml PPS	
	L015-014	A-910G with 600ml cup	
	L015-024	A-910G with 750ml PPS	
1a	L015-801	A928, 1.0 needle/seat/cap kit	1
	L015-803	A928, 1.4 needle/seat/cap kit	1
	L015-804	A928, 1.7 needle/seat/cap kit	1
	L015-806	A928, 2.0 needle/seat/cap kit	1
	L015-809	A928, 2.8 needle/seat/cap kit	1
	L015-850	A910, 1.1 needle/seat/cap kit	1
	L015-851	A910, 1.4 needle/seat/cap kit	1
	L015-854	A910, 1.8 needle/seat/cap kit	1
	L015-852	A910, 2.0 needle/seat/cap kit	1
	L015-853	A910, 2.5 needle/seat/cap kit	1
	L015-864	A910, 3.0 needle/seat/cap kit	1
1b	L015-840	Spring clip outside air cap, A928	1
	L015-861	Nylon ring inside air cap, A928	1
	L015-856	Nylon ring inside air cap, A910	1
1c	L015-841	Air cap ring, A928	1
	L015-855	Air cap ring, A910	1
2	L015-810	Packing screw	1
	L015-888	Packing screw SS	1
* 3	L015-811	Packing	1
4	L015-812	Washer	1
5	L015-813	Spring	1
6	L015-814	Gun body, A928	1
	L015-890	Gun body, A910SS	1
7	L015-815	Fan control assy (suction versions)	1
	L015-858	Fan control assy (A910/A928 G ver)	1
*7a		Shaft seal (fan control) (L004-571 fits)	1

Pos.	Part nos.	Description	Qty.
* 8	L015-816	Gasket	1
9	L015-817	Bushing	1
10	L015-818	Needle spring	1
11	L015-819	Material control knob	1
12	L015-820	Air inlet fitting	1
13	L015-821	Air flow control valve	1
*		Shaft seal (air flow control)	1
14	L015-822	Trigger	1
15	L015-823	C-clip	1
16	L015-824	Trigger pin	1
17	L015-825	Air valve seat assy	1
*		Shaft seal (air valve)	1
*18	L015-826	O-ring (alternate L004-571 HD viton)	1
19	L015-827	Air valve stem	1
*		Valve seat (air valve stem)	1
20	L015-828	Air valve spring	1
21	L015-829	Fluid inlet fitting	1
	L015-889	Fluid inlet fitting SS	1
22	L015-831	Regulator assy, 5 port	1
30	L015-832	Container assy, A928	1
	L015-857	Container assy, A910	1
31	L015-842	Lid assy, A910/A928	1
34	L015-833	Container gasket	1
35	L015-844	Anti-Drip baffle (2-3/4" snap-in version)	1
	L015-834	Anti-Drip baffle (overlap seal version)	1
36	L015-835	Container only, A910/A928	1
37	L015-836	Gravity cup complete, 600cc	1
38	L015-837	Gravity cup Lid	1
39	L015-838	Gravity cup gasket	1
40	L015-839	Gravity cup bare, 600cc	1
41	L015-859	Fluid inlet fitting, A910G	1

#### Accessories:

*	L015-830	Seal kit consisting of items marked " * "
42	L011-587	Suction filter, 170m, 3.8D x 4.2H cm
43	L011-887	Air reg kit to push HD Hybrid Latex paint
	L015-349	Manual A-900 & A-928 HVLP
	L015-703	Tool kit, A910
	L015-704	Tool kit, A928G

Specifications subject to ch