

A-728 HVLP NON-BLEEDER TURBINE SPRAY GUN

NOZZLE SIZING - A-728 HVLP

There are 6 sizes of fluid nozzle available:

Material being sprayed

Fine finish work with stains, lacquer	1.0 mm diameter (.039")
enamels, automotive base/clear.	
Medium speed with lacquers, enamels,	1.3 mm diameter (.051")
urethanes, clear coats.	
Normal output with lacquers, enamels,	1.5 mm diameter (.059")
urethane, varnish, automotive primers	(standard)
Higher output with primers, industrial finishes	1.8 mm diameter (.071")
Latex and oil paints	2.0 mm diameter (.079")
Higher output in latex and oil paints.	2.8 mm diameter (.110")

Nozzle chart

Material	1.0 mm	1.5 mm	2.0 mm
clear finishes (up to 20 sec)	best	ok	no
colour finishes (20 - 40 sec)	ok	best	ok
multicolour & heavy latex (40+ sec)	no	no	best

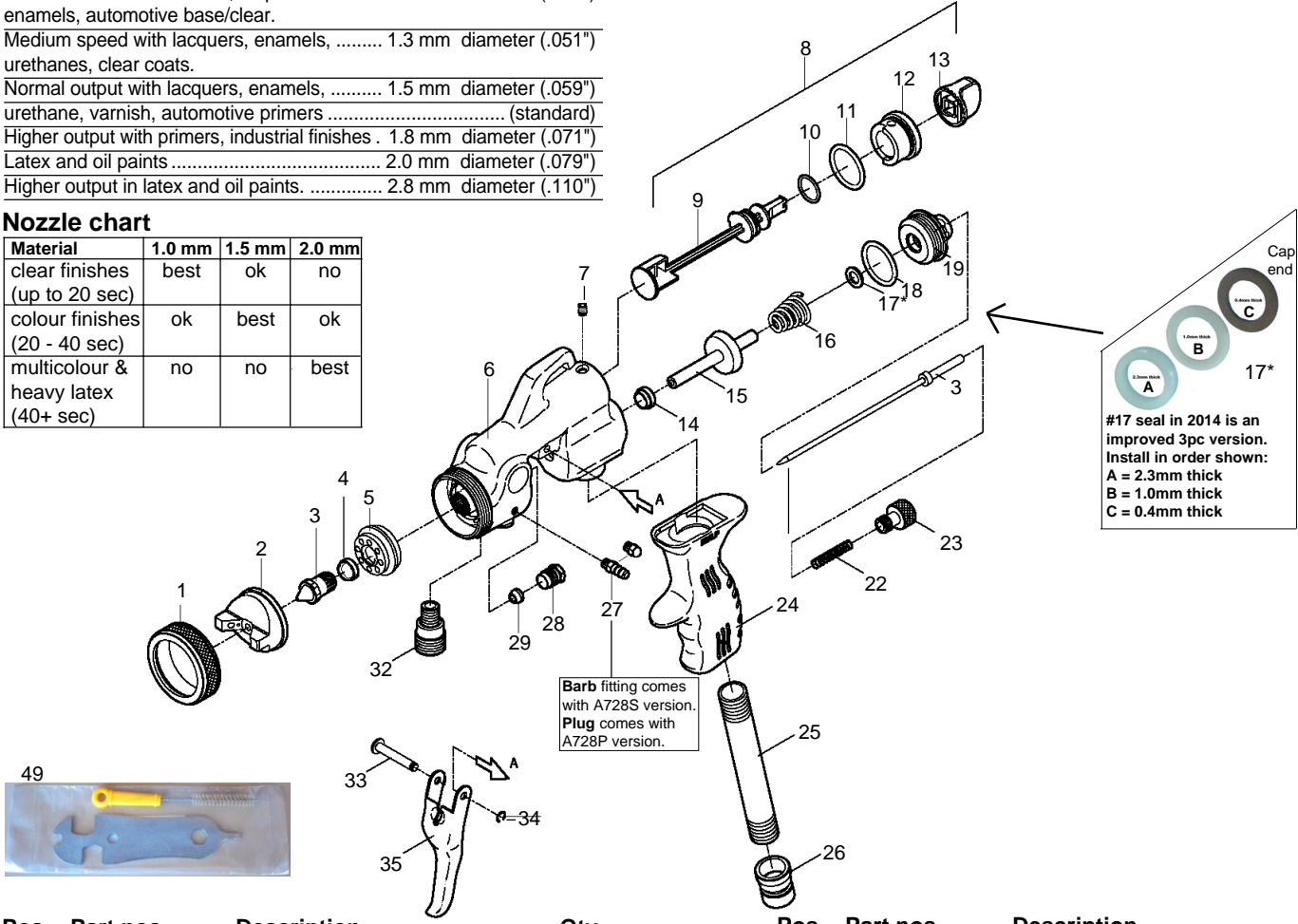

Barb fitting comes with A728S version. Plug comes with A728P version.

Cap end
#17*
A = 2.3mm thick
B = 1.0mm thick
C = 0.4mm thick

Pos.	Part nos.	Description	Qty.
	L081-050	A-728S HVLP spray gun with cup	
	L081-051	A-728P HVLP spray gun no cup	
1	L081-330	Retaining ring, aircap	1
2	L081-321	A728, 1.0-1.5 air cap	1
	L081-325	A728, 1.8-2.0 air cap	1
	L081-326	A728, 2.8 air cap	1
3	L081-311	A728, 1.0 needle/nozzle kit	1
	L081-312	A728, 1.3 needle/nozzle kit	1
	L081-313	A728, 1.5 needle/nozzle kit (std.)	1
	L081-314	A728, 1.8 needle/nozzle kit	1
	L081-315	A728, 2.0 needle/nozzle kit	1
	L081-316	A728, 2.8 needle/nozzle kit	1
* 4	L081-331	Seal, nozzle	1
5	L081-332	Ring, air distributing	1
6	L081-333	Gun body, A728	1
7	L081-334	Set screw, M4 x 0.7	1
8	L081-335	Fan control assembly	1
9	L081-336	Control stem	1
*10	L081-337	O-ring, inner	1
*11	L081-338	O-ring, outer	1
12	L081-339	Bushing	1
13	L081-341	Control knob, fan adjusting	1
*14	L081-342	Air Valve Seal, 10mm OD 1pc older guns	1
	L081-345	Air Valve Seal, 12mm OD 3pc newest	1
15	L081-343	Air control valve	1
*16	L081-344	Spring, conical	1
*17	L081-346	Seal (3 pcs new ver 2014)	1
*18	L081-347	O-ring	1
19	L081-348	Cap, air valve	1

Pos.	Part nos.	Description	Qty.
*22	L081-349	Spring, needle	1
23	L081-351	Control knob, fluid	1
24	L081-352	Handle, molded	1
25	L081-354	Air inlet pipe	1
26	L081-355	Air inlet fitting, M-QC	1
27	L081-356	Barb, 1/16" H x M8-0.75 x 90 deg.	2
	L081-365	Plug, for pressure feed, M8 x 0.75	1
28	L081-358	Packing nut	1
*29	L081-357	Packing	1
32	L081-359	Inlet fitting, 3/8-NPS-M	1
33	L081-361	Axle, trigger	1
34	L081-362	Snap ring	1
35	L081-363	Trigger	1

Accessories:

* L081-370	Seal kit consisting of items marked " * "
L015-609	Suction strainer (each)
L015-610	Suction strainer (pkg/5)
L080-999	Manual A-728 HVLP
49 L081-371	Tool kit A-728

PPS 1.0 3m (before 2023)



1 Liter metal Pot

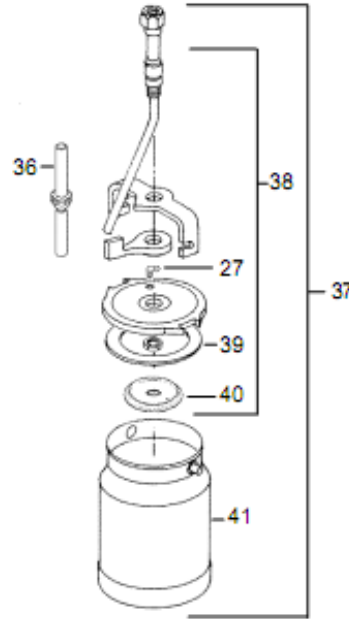

PPS 2.0 3m



Pos.	Part nos.	Description	Qty.
1	L034-304	Cup & Collar, Pressure Feed 950 mL	1
2	L034-313	Lid & Liner, 950 mL	1
3	L034-339	Hose, 1/8" ID Silicone PK/2	1
4	L034-320	Gun adaptor, #18 Suction	1
5	L034-305	Cup & Collar, Pressure Feed 850 mL	1
6	L034-354	Lid & Liner, 850 mL	1
7	L034-359	Gun adaptor, #S18 Suction	1
27	L081-356	Barb, 1/16" H x M8-0.75 x 90 deg.	1
36	L081-364	Check valve assy.	1
37	L015-832	Container assy, A728/928	1
38	L015-842	Lid assy, A728/928	1
39	L015-833	Container gasket	1
40	L015-844	Anti drip baffle	1
41	L015-835	Container only	1